

« The Locator » Boundless information for enterprises

Ralf P. Meyer, AGIT mbH (D)

The Locator



2nd seminar on cross-border territorial observation
 Budapest (HU), 30th September 2014



Background & project



► Euregio Meuse-Rhine (EMR)

- **Established:** 1976
- **Languages:** Dutch, French, German
- **Population:** 3.9 mln.
- **Largest cities / region:**
 - Aachen (D)
 - Liège (B - WAL)
 - Maastricht (NL)
 - Hasselt (B - VLA)
 - Eupen (B - DGB)
- **Area:** 12.882 km²
- **GDP (2009):** € 96.8 bln.

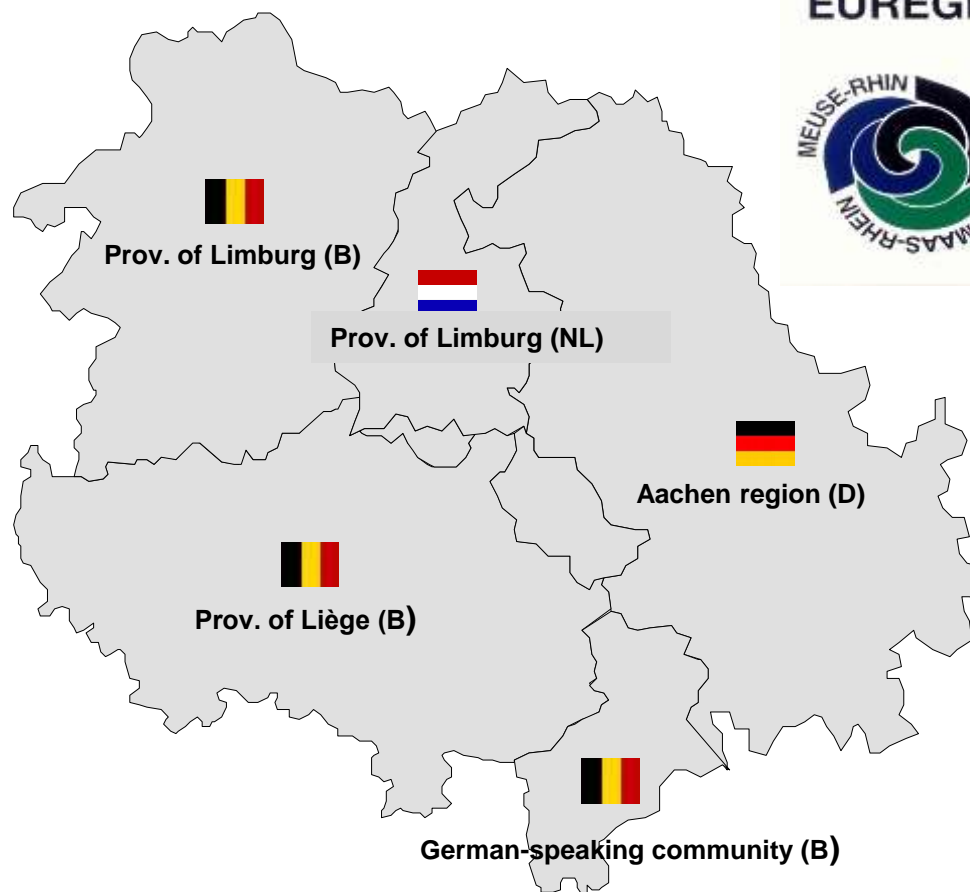

Sources: National statistic agencies, Eurostat, Euregio Meuse-Rhine



▶ AGIT: Development agency for Aachen region (D)

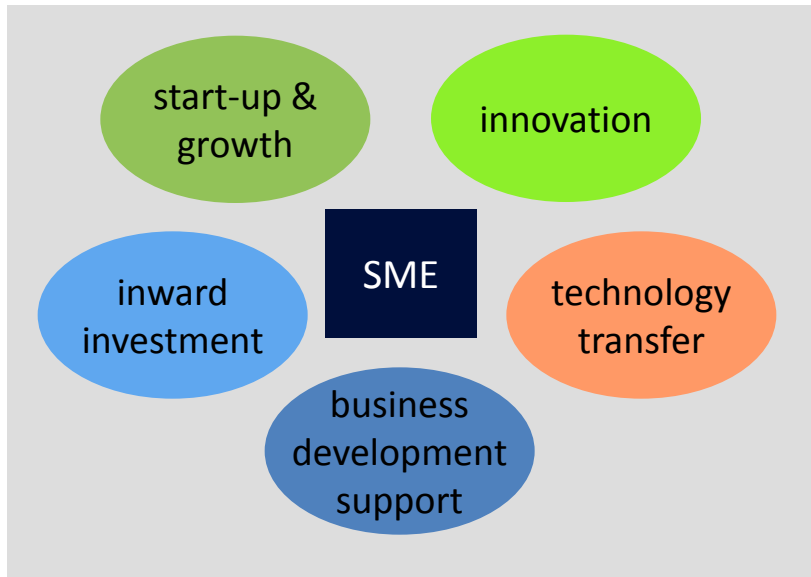

▶ Cross-border / international activities & projects as a main pillar:

- Focus on innovation & SMEs (e.g. Cross-border innovation funds (GCS), awarded with „Sail of Papenburg 2014“ (AEBR))



- Focus on territorial monitoring (e. g. interactive webservice on cross-border regional statistics for EMR)





▶ Starting point: Four regions – four solutions

The image shows a map of the Limburg region, with four specific locations highlighted and linked to digital solutions:

- POM / AO (B)**: Located near Maastricht, associated with the Belgian flag and a screenshot of the 'Agri' website showing a colorful agricultural map.
- Prov. Limburg (NL)**: Located near Maastricht, associated with the Dutch flag and a screenshot of the 'REBIS' website with the text 'Bedrijventerreinmonitor' and 'Klik hier'.
- AGIT (D)**: Located near Aachen, associated with the German flag and a screenshot of the 'gIstRA' website showing a map.
- spi (B)**: Located near Liège, associated with the Belgian flag and a screenshot of the 'spi' website's 2010-2011 anniversary page.



► Objectives

Develop a user-friendly webGIS-application providing location & settlement information for companies willing to (re)locate in the Euregio Meuse-Rhine as a concrete contribution for economic development and further integration of the cross-border region

- Establish an **actual** and **esp. cross-border comparable** information service
- Create market transparency / market **business parks & commercial real estates** across national borders
- Additionally: Information on **already established companies & settlement issues**
- Multilingual – Open standards (OGC-conform) – based on & compatible to regional solutions



▶ Target groups

1. **International & national companies**, not familiar with cross-border region of Belgium – The Netherlands – Germany
2. **Businesses out of the Euregio Meuse-Rhine** expanding their activities across borders
3. **Local businesses** interested to use the new opportunities & functionalities (e.g. perimeter search)
4. **Public sector / intermediate institutions / commercial real estate agencies** in order to provide information to companies



▶ The process

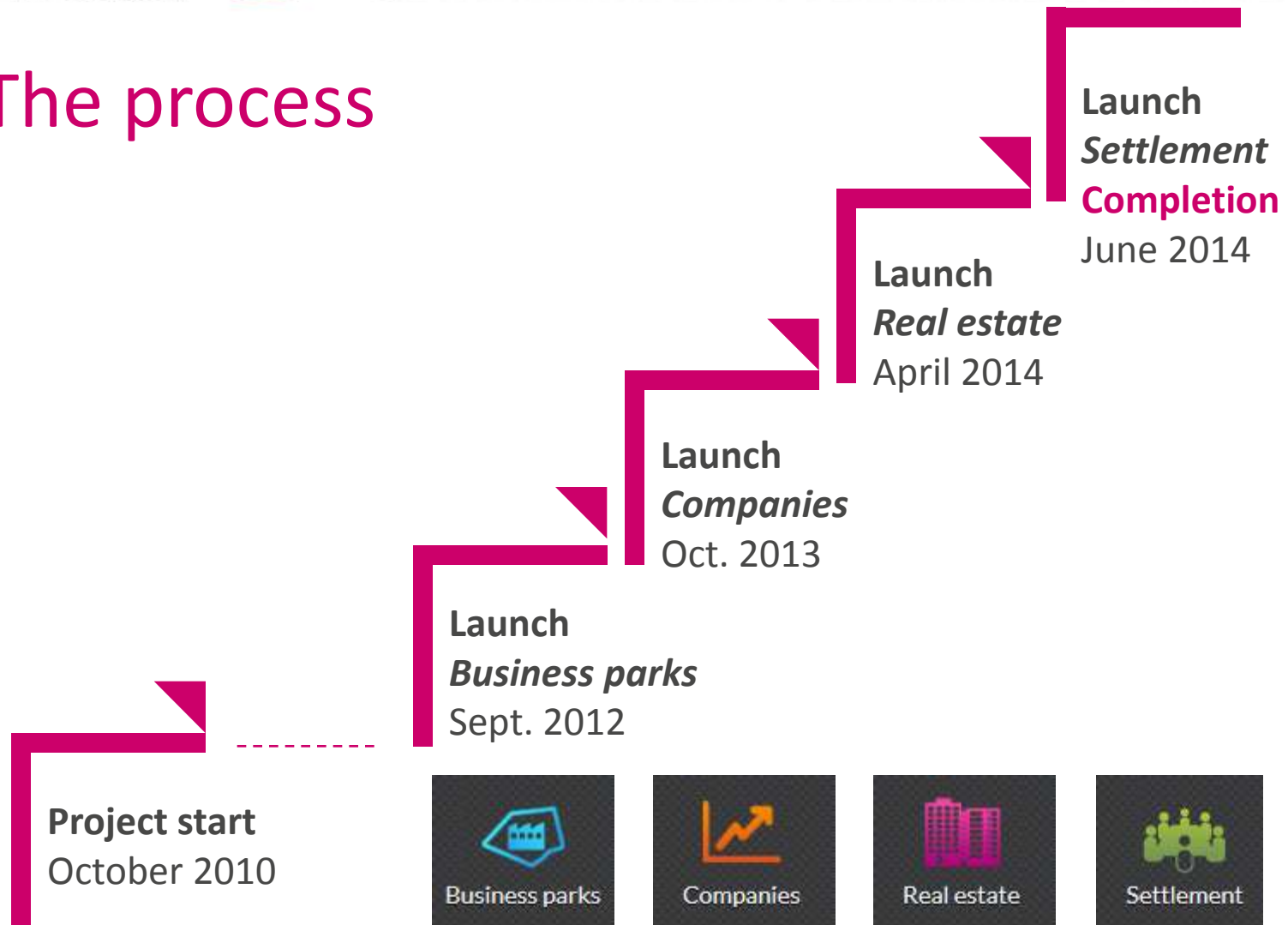



Challenges & solutions

► Challenge



Lack of insight

What is already existing?

- Which information is available on which level?
- Who are the relevant actors?
- Who is responsible for what?
- How does the updating of information function (procedure)?
- Liability & sustainability of data?
- Use of geodata?
- How does the technical environment look like?

► Solution

Technical & environmental analysis



► Challenge



Cross-border integration
How to harmonize information?

- E.g. business parks: classification of approx. 150 data categories
- Available data vs. desired information
- Where is the common ground?
- Is it possible to increase the quality of information?

► Solution

Development of a joint data model



► Challenge



Data relevance

How to keep information up-to-date?

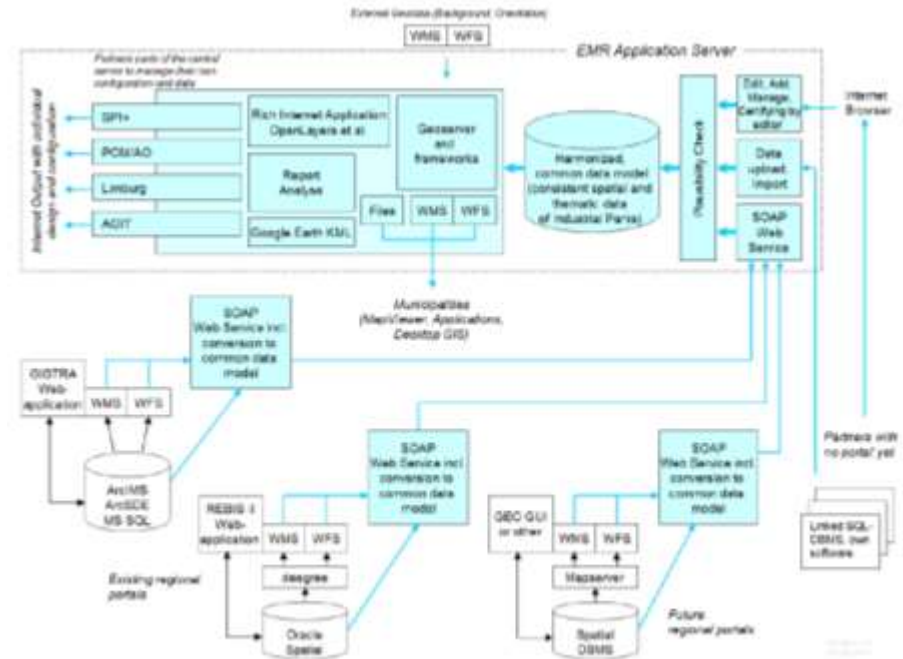

► Solution

Data-at-the-source / SOAP interfaces

► Challenge



Low-threshold usability

How to implement an easy-to-use solution?

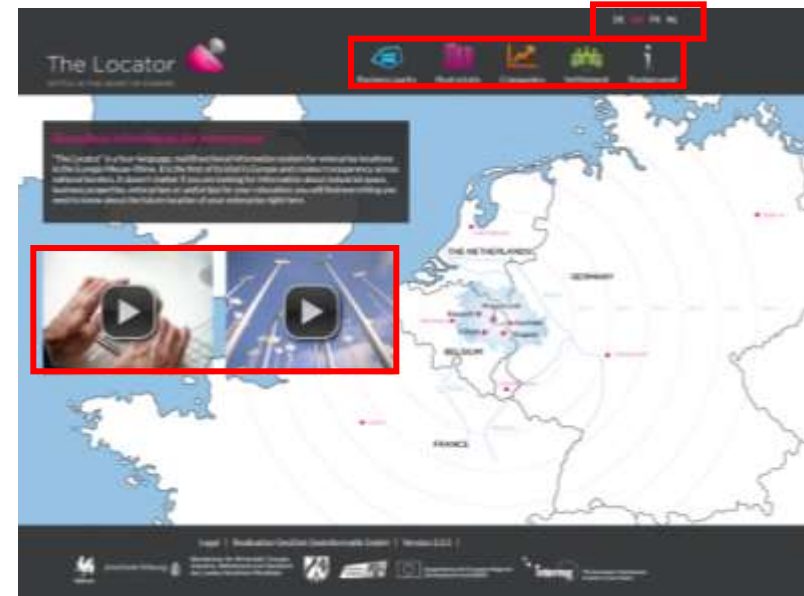

► Solution

Simplify the homepage



► Challenge



Competition vs. transparency
How to build trust?



Transparent Borders

ero sit ar
ibulum e
ittis tem
, eu vulp
are hip
est. Mau
e sit amet
lvinar fac
am dui m



di tristique senectus et netus et malesuada
ero sit amet quam egestas semper. Aenean

► Solution

« Just do it »: Transparency creates trust
& trust creates more transparency



How it works

Business parks: Search

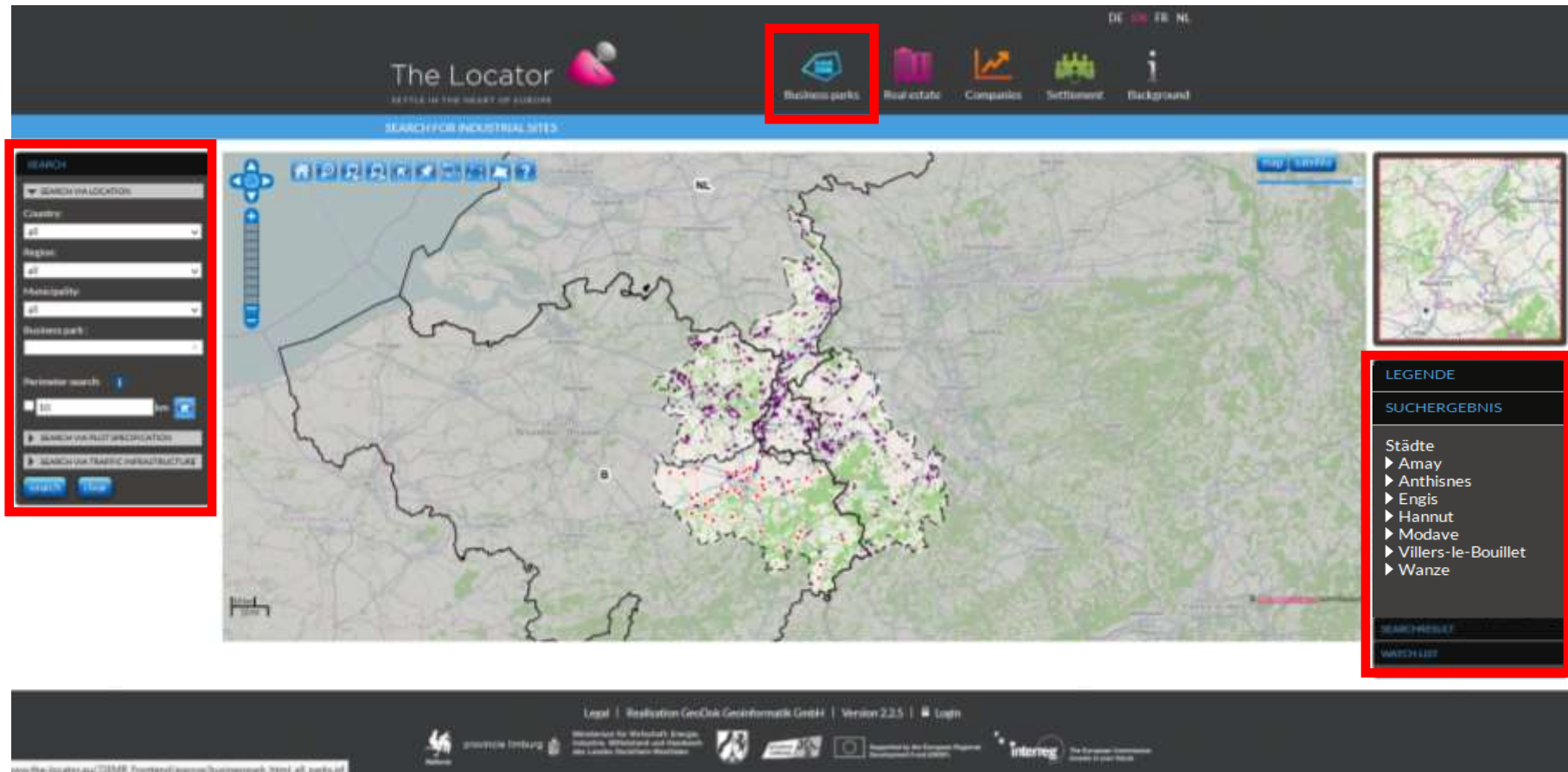

The screenshot displays the 'The Locator' website interface for searching business parks. The top navigation bar includes the logo and a menu with 'Business parks' highlighted in a red box. Below the navigation bar is a search panel on the left, also highlighted in a red box, containing dropdown menus for 'Country', 'Region', and 'Municipality', a text input for 'Business park', and a 'Perimeter search' section. The main area features a map of a region with numerous colored markers representing business parks. On the right side, a legend titled 'LEGENDE' and 'SUCHERGEBNIS' lists several municipalities: Amay, Anthisnes, Engis, Hannut, Modave, Villers-le-Bouillet, and Wanze. The footer contains legal information, logos for 'Innovative Funding' and 'interreg', and the URL 'www.the-locator.eu/22MR_frontend/pages/businesspark.html_all_parks.html'.

Business parks: Results

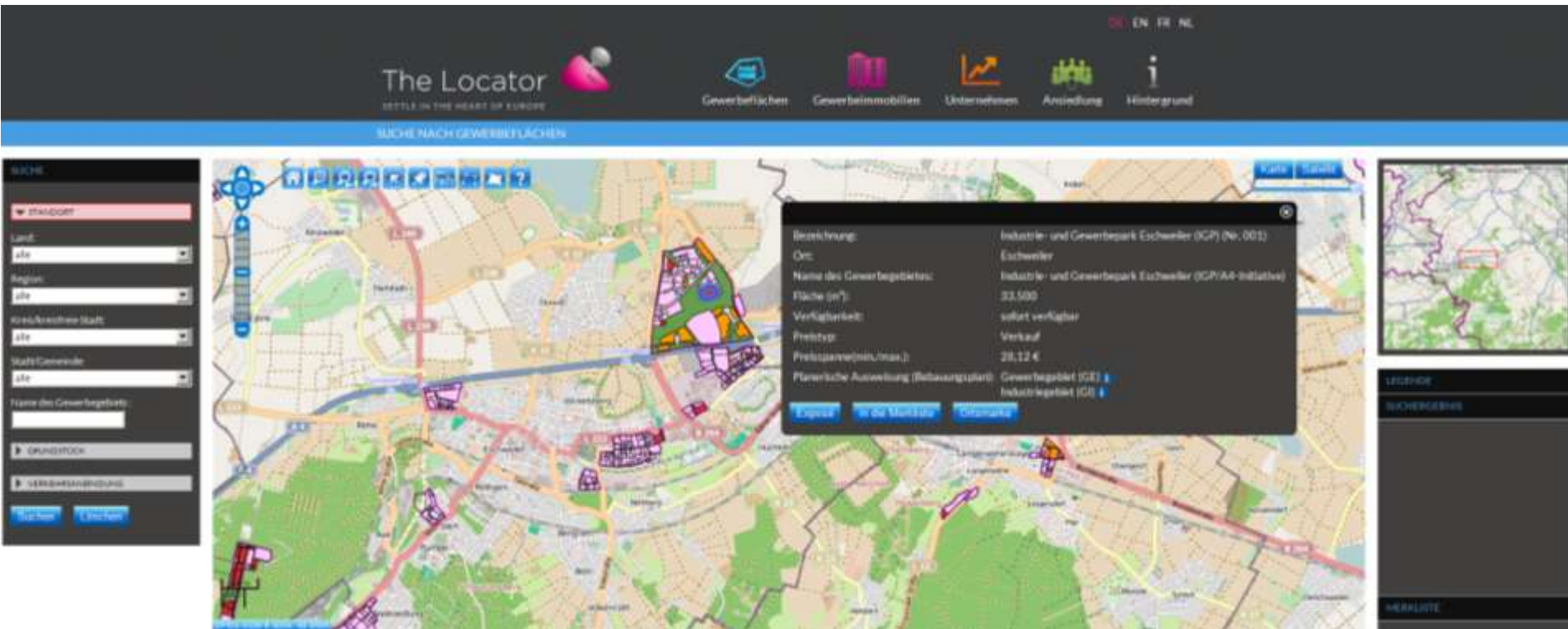

The Locator
SETTLER IN THE HEART OF EUROPE

EN FR NL

Gewerbeflächen Gewerbemobilien Unternehmen Ansiedlung Hintergrund

SUCHE NACH GWERBEFLÄCHEN

SUCHE

STANDORT

Land: alle

Region: alle

Kreis/Anlieger Stadt: alle

Stadt/Gemeinde: alle

Name des Gewerbegebietes:

GRUNDSTÜCK

VERKEHRSANBINDUNG

Industrie- und Gewerbepark Eschweiler (IGP) (Nr. 001)

Ort: Eschweiler

Name des Gewerbegebietes: Industrie- und Gewerbepark Eschweiler (IGP) (Nr. 001)

Fläche (m²): 33.500

Verfügbarkeit: vollst. verfügbar

Preistyp: Verkauf

Preispaarweise/Max.: 28,12 €

Planerische Ausweisung (Bebauungsplan): Gewerbegebiet (IG) | Industriegebiet (IG) |

Export | Wo? | Details

LEISTUNG

SUCHERGEBNIS

NEARLAGE



Fact sheet

- ▶ Maps
- ▶ Textual information
- ▶ Photos

FACT SHEET: ANNA-GELÄNDE
(ALSDORF, AACHEN REGION, GERMANY)

map view



CONTACT PERSON

First name Last name:	Herr Christoph Kemperdick
Organization name:	NRW Urban
Department:	Aachen
Tel:	+49(0)24147019-20
Fax:	+49(0)24147019-30
Email:	christoph.kemperdick@leg.nrw.de
Homepage:	http://www.nrw-urban.de

INFORMATION ABOUT THE PLOT

Description:	Anna-Gelände (Nr. 003)
Size of plot (m2):	6,454 m²
Availability:	immediately available
Utilization:	not specified
Ownership:	public ownership
Options:	no
Freely divisible:	yes

INFORMATION ABOUT THE INDUSTRIAL SITE

Price Type:	sale
Price (m² max.):	€50 - €50
Location in urban framework:	outskirts
Zone (land use plan):	Gewerbegebiet (GE)
Gross area:	8,01 ha
Net area:	5,13 ha
Largest available area:	8,453 m²







Real estates: Search



The screenshot displays the 'The Locator' web application interface. At the top, the logo 'The Locator' is accompanied by the tagline 'SETTLER IN THE HEART OF EUROPE'. A navigation bar includes icons for 'Business parks', 'Real estate' (highlighted with a red box), 'Companies', 'Settlement', and 'Background'. Below this is a pink banner with the text 'SEARCH FOR COMMERCIAL REAL ESTATES'. The main area features a map of a region with numerous pink circular markers, each containing a number. To the left of the map is a search sidebar with fields for 'Country', 'Region', 'Municipality', 'Business park', 'Perimeter search' (set to 30 km), 'Type', 'Purchase conditions', and 'Size (sqm)'. To the right of the map is a legend titled 'LEGEND' with entries for 'Real estate' (pink circle), 'selected real estate' (red circle), 'Country' (black outline), and 'Municipality' (grey outline). At the bottom of the interface, there is a footer with logos for 'provincia inführung', 'Ministerium für Wirtschaft, Energie, Industrie, Mittelstand und Tourismus', 'interreg', and 'The European Commission'.



Real estates: Results

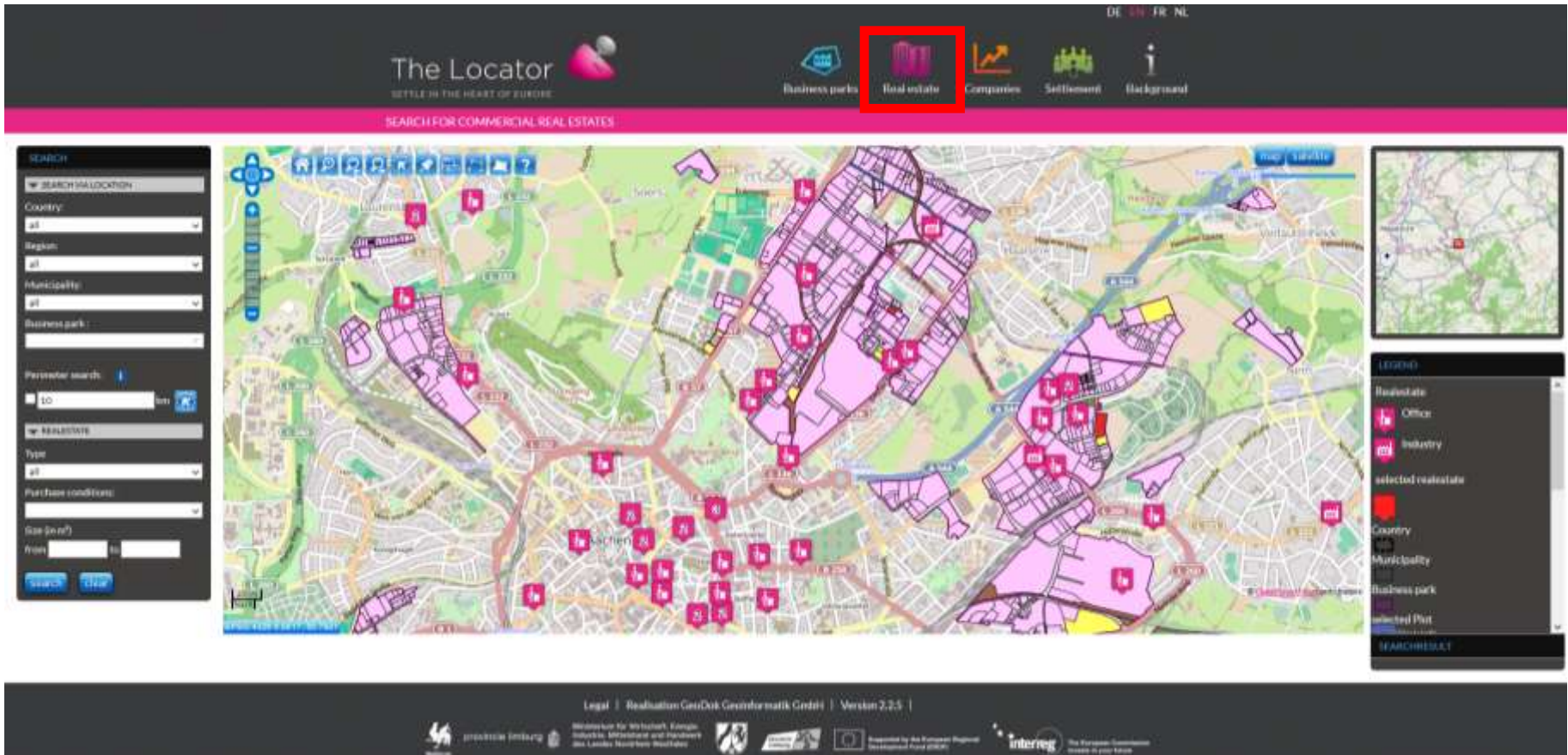

The screenshot displays the 'The Locator' website interface. At the top, the logo 'The Locator' is accompanied by the tagline 'SETTLE IN THE HEART OF EUROPE'. Navigation tabs include 'Business parks', 'Real estate' (highlighted with a red box), 'Companies', 'Settlement', and 'Background'. A search bar is located on the left side, with fields for 'Country', 'Region', 'Municipality', and 'Business park'. Below these are 'Parameter search' and 'RESULTS' sections. The main area features a map with numerous red and pink markers indicating real estate locations. A legend on the right side identifies the markers: 'Real estate' (pink square), 'Office' (red square with 'b'), 'Industry' (red square with 'i'), 'selected real estate' (red square with 's'), 'Country' (red square with 'c'), 'Municipality' (red square with 'm'), and 'Business park' (red square with 'p'). The bottom of the page contains legal information, logos for 'interreg' and 'European Regional Development Fund', and the website URL 'www.the-locator.eu'.



Companies: Search

The screenshot displays the 'The Locator' web application interface. At the top, the logo and navigation menu are visible, with the 'Companies' option highlighted in a red box. Below the navigation bar is a search sidebar on the left with various filters like Country, Region, Municipality, and Business park. The main area features a map of the Netherlands with orange heatmaps indicating company density. A legend on the right explains the heatmap colors and provides options for search results and downloading data. The footer contains legal information, logos for the Government of North Brabant and the European Union, and the version number 2.2.5.

Companies: Results macro level

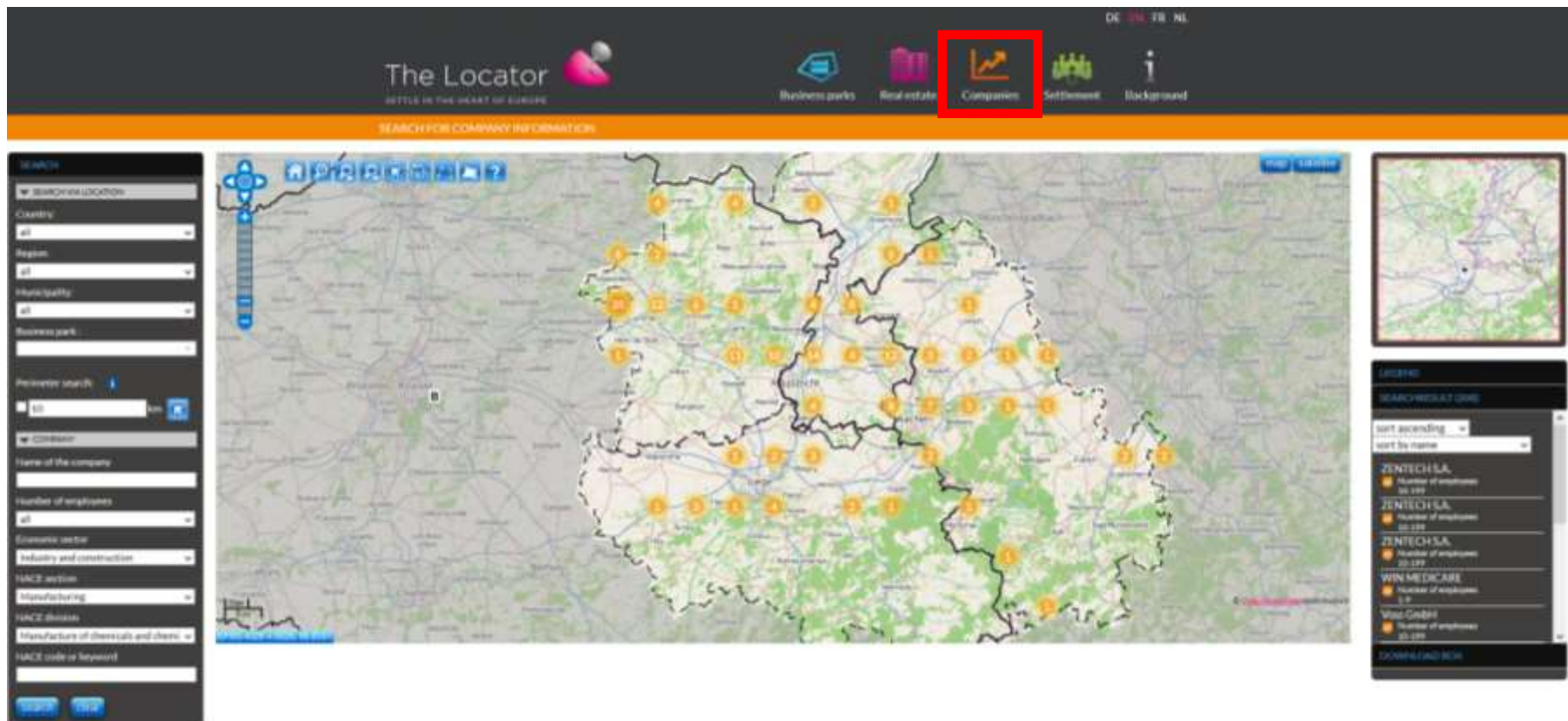

The screenshot displays the 'The Locator' website interface. At the top, the logo and navigation menu are visible. The 'Companies' menu item is highlighted with a red box. Below the navigation bar, a search bar is present. The main content area features a map of Europe with numerous orange dots indicating company locations. A sidebar on the left contains search filters, and a sidebar on the right shows search results for 'ZENTECH S.A.'.

Navigation Menu:

- Business parks
- Real estate
- Companies**
- Settlement
- Background

Search Filters (Left Sidebar):

- Country: all
- Region: all
- Municipality: all
- Business park: [empty]
- Previous search: [empty]
- Company: [empty]
- Name of the company: [empty]
- Number of employees: all
- Economic sector: Industry and construction
- NACE activity: Manufacturing
- NACE division: Manufacture of other parts and accessories
- NACE code or keyword: [empty]

Search Results (Right Sidebar):

Company Name	Number of employees
ZENTECH S.A.	38.000
ZENTECH S.A.	38.000
ZENTECH S.A.	38.000
WIN MEDICARE	20.000
Winmedicare	20.000
Winmedicare	20.000

Companies: Results micro level

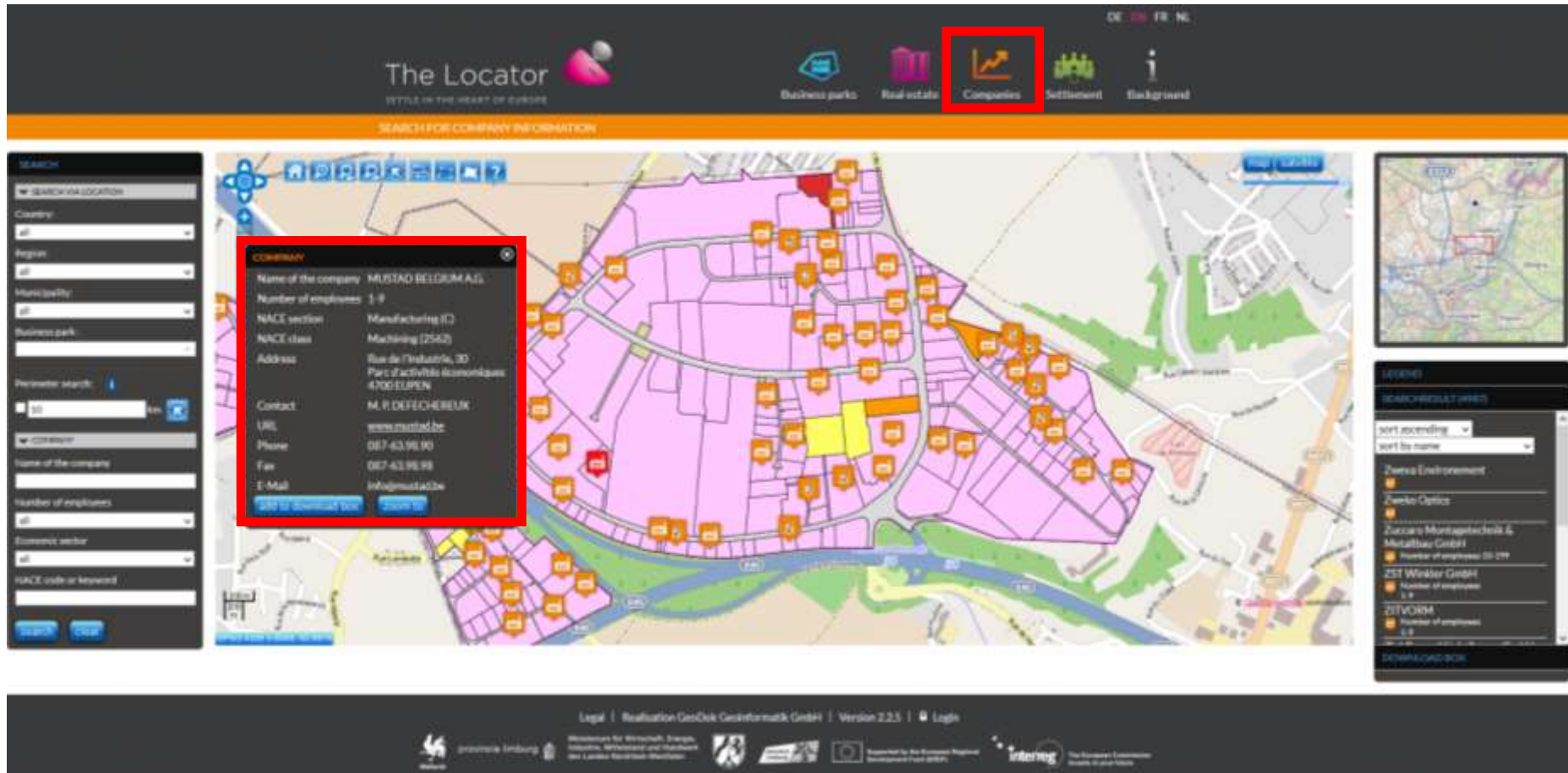

The screenshot displays the 'The Locator' web application interface. At the top, navigation icons for 'Business parks', 'Real estate', 'Companies' (highlighted with a red box), 'Settlement', and 'Background' are visible. The main area shows a map with numerous orange company markers. A popup window, also highlighted with a red box, provides detailed information for a selected company:

COMPANY	
Name of the company	MUSTAD BELGIUM A.S.
Number of employees	1-9
NACE section	Manufacturing (D)
NACE class	Machining (2542)
Address	Rue de l'Industrie, 30 Parc d'Activités Economiques 4700 EUPEN
Contact	M. P. DEFECHEREUX
URL	www.mustad.be
Phone	087-63.96.90
Fax	087-63.96.98
E-Mail	info@mustad.be

Buttons for 'GET TO SETTLEMENT TOOL' and 'CLOSE' are located at the bottom of the popup. The left sidebar contains search filters for Country, Region, Municipality, Business park, Perimeter search, and Economic sector. The right sidebar shows a 'SEARCH RESULTS' list with entries like 'Zwebo Eintrouwen', 'Zwebo Optics', and 'Zwebo Montagetackels & Metallbau GmbH'.



Settlement: Overview EMR

The screenshot shows the 'Settlement' section of the website. The navigation bar at the top includes icons for Business parks, Real estate, Companies, Settlement (highlighted in red), and Background. Below the navigation bar, there is a search bar and a sidebar with the following sections:

- EUREGIO**
 - Profile
 - Location factors
 - Settlement specifics
- AACHEN REGION**
 - Profile
 - Location factors
 - Settlement specifics
- PROVINCE OF LIMBURG (NL)**
 - Profile
 - Location factors
 - Settlement specifics
- PROVINCE OF LIEGE**
 - Profile
 - Location factors
 - Settlement specifics
- PROVINCE OF LIMBURG (BE)**
 - Profile
 - Location factors
 - Settlement specifics

The main content area features a map of the Euregio Meuse-Rhine region, showing the confluence of the Meuse and Rhine rivers. Below the map, the text reads:

Euregio Meuse-Rhine: a high-technology region in the force field of Europe to settle your company

The triangle formed by Belgium, Germany and the Netherlands is in the economic heart of Europe. From your location in the Euregio Meuse-Rhine you are able to reach 100 million people within only four hours. This means one quarter of the EU purchasing power!

The smartest corporate location in Western Europe

The Euregio Meuse-Rhine is embedded between the Flemish Diamond (Belgium) in the West, the Rhein-Ruhr conurbation (Germany) in the East and the Randstad Holland (The Netherlands) in the Northwest. Within this main-delta, the global gateways to or from the European mainland are located. Including international activities, 45% of the European logistic market is located in this area.



Settlement: Overview & details regions

The screenshot shows the 'The Locator' website interface. At the top, there is a navigation bar with icons for 'Business parks', 'Real estate', 'Companies', 'Settlement' (highlighted with a red box), and 'Background'. Below the navigation bar, there is a search bar and a sidebar with various filters. The main content area features a map of the Aachen region, with several areas highlighted in green. Below the map, there is a section titled 'Purchase, Rent, and Lease your company premises' with sub-sections for 'Rental and lease' and 'Purchase'.

Purchase, Rent, and Lease your company premises

If you have already decided to locate in the Region of Aachen, you need premises or real estate to operate your business. These can be rented, leased, or purchased.

Rental and lease

In contrast to the classical rent, a lease interest is paid with the lease option. The payment amount depends on the generated revenue of the company.

Purchase

If you are considering purchasing premises or real estate you should be aware that German law prohibits leaseholds. Thus, a building can only be purchased together with its related property. This also applies to any planned new construction at the



The future

The Locator

Launch: 17th June 2014 / Aachen (D)



The Locator





Next steps

„The Locator“ core group

- ▶ Joint cooperation agreement (one partner per region, for the time being until mid 2019)
- ▶ Maintenance & hosting
- ▶ Marketing & communication (SEO, ads, magazines, fairs, new partners)
- ▶ Further development of the portal (e.g. mobility / logistics)



How to find us

- ▶ www.the-locator.eu
- ▶ www.the-locator.de
- ▶ www.the-locator.nl
- ▶ www.the-locator.be

ONE TOOL, MANY OPTIONS



Business parks



Real estate



Companies



Settlement

Your contact: Ralf P. Meyer, AGIT mbH (D), r.meyer@agit.de



provincie limburg



Ministerium für Wirtschaft, Energie,
Industrie, Mittelstand und Handwerk
des Landes Nordrhein-Westfalen



Supported by the European Regional
Development Fund (ERDF)



The European Commission
invests in your future